

EMB3 Dual Digital Transistors (PNP+PNP)

FEATURES

- Two DTA143T chips in a package
- Transistor elements are independent, eliminating interference
- Mounting cost and area can be cut in half

MARKING: B3

Absolute maximum ratings(Ta=25°C)

Parameter	Symbol	Limits	Unit
Collector-base voltage	$V_{(BR)CBO}$	-50	V
Collector-emitter voltage	$V_{(BR)CEO}$	-50	V
Emitter-base voltage	$V_{(BR)EBO}$	-5	V
Collector current	I_C	-100	mA
Collector Power dissipation	P_C	150	mW
Operation Junction and Storage Temperature Range	T_J, T_{stg}	-55~+150	°C

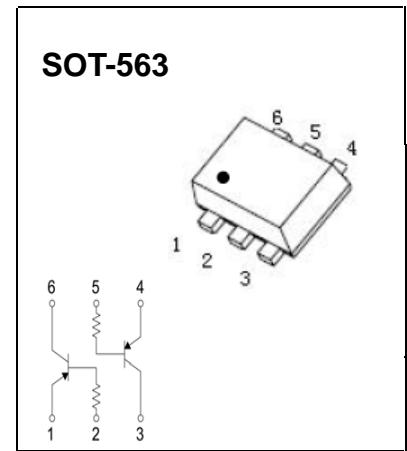

Electrical characteristics (Ta=25°C)

Parameter	Symbol	Min.	Typ	Max.	Unit	Conditions
Collector-base breakdown voltage	$V_{(BR)CBO}$	-50			V	$I_C=-50\mu A$
Collector-emitter breakdown voltage	$V_{(BR)CEO}$	-50			V	$I_C=-1mA$
Emitter-base breakdown voltage	$V_{(BR)EBO}$	-5			V	$I_E=-50\mu A$
Collector cut-off current	I_{CBO}			-0.5	μA	$V_{CB}=-50V$
Emitter cut-off current	I_{EBO}			-0.5	μA	$V_{EB}=-4V$
Collector-emitter saturation voltage	$V_{CE(sat)}$			-0.3	V	$I_C=-5mA, I_B=-2.5mA$
DC current transfer ratio	h_{FE}	100		600		$V_{CE}=-5V, I_C=-1mA$
Input resistance	R_1	3.29	4.7	6.11	K Ω	
Transition frequency	f_T		250		MHz	$V_{CE}=10V, I_E=-5mA, f=100MHz$

SOT-563 Package Outline Dimensions

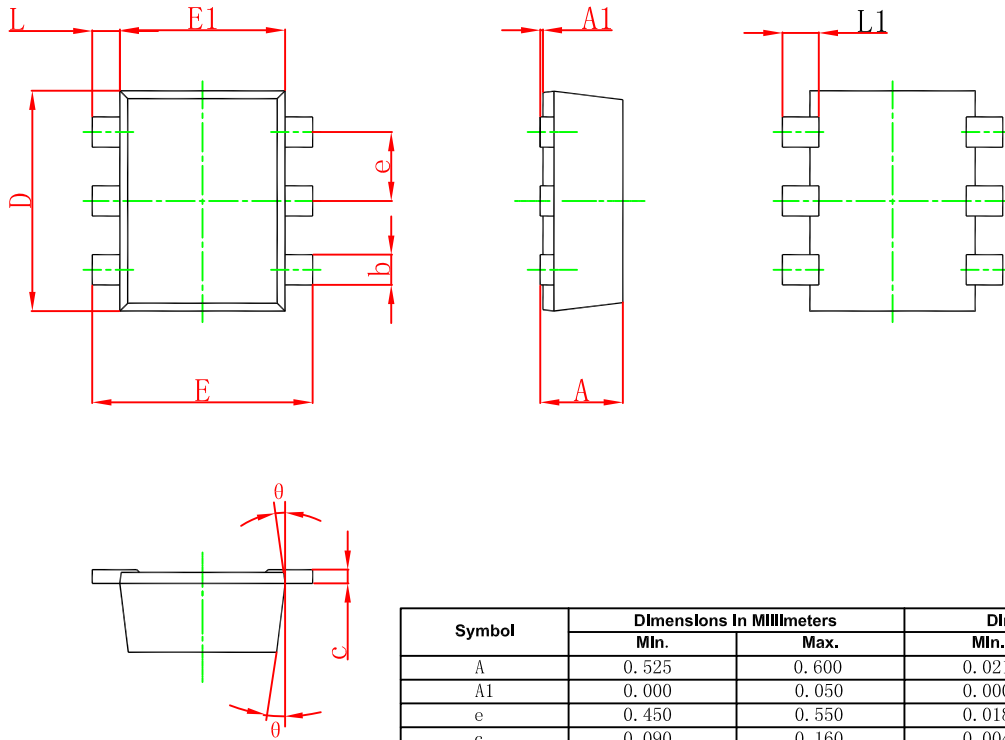

Symbol	Dimensions In Millimeters		Dimensions In Inches	
	Min.	Max.	Min.	Max.
A	0.525	0.600	0.021	0.024
A1	0.000	0.050	0.000	0.002
e	0.450	0.550	0.018	0.022
c	0.090	0.160	0.004	0.006
D	1.500	1.700	0.059	0.067
b	0.170	0.270	0.007	0.011
E1	1.100	1.300	0.043	0.051
E	1.500	1.700	0.059	0.067
L	0.100	0.300	0.004	0.012
L1	0.200	0.400	0.008	0.016
θ	7 ⁰ REF.		7 ⁰ REF.	

SOT-563 Suggested Pad Layout

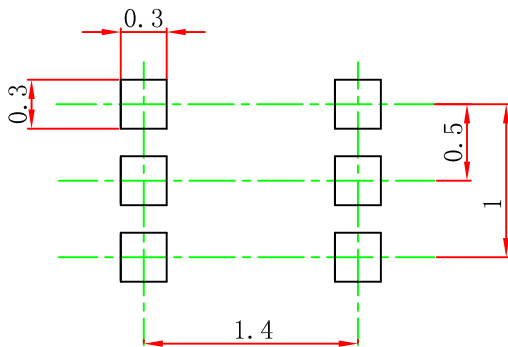

Note:

1. Controlling dimension: in millimeters.
2. General tolerance: $\pm 0.05\text{mm}$.
3. The pad layout is for reference purposes only.

NOTICE

JSCJ reserves the right to make modifications, enhancements, improvements, corrections or other changes without further notice to any product herein. JSCJ does not assume any liability arising out of the application or use of any product described herein.

SOT-563 Tape and Reel

SOT-563 Embossed Carrier Tape

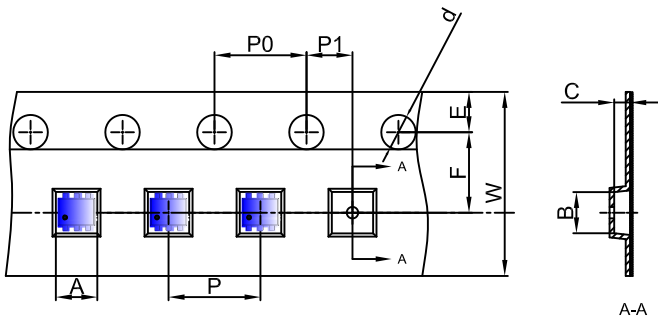

Packaging Description:

SOT-563 parts are shipped in tape. The carrier tape is made from a dissipative (carbon filled) polycarbonate resin. The cover tape is a multilayer film (Heat Activated Adhesive in nature) primarily composed of polyester film, adhesive layer, sealant, and anti-static sprayed agent. These reeled parts in standard option are shipped with 3,000 units per 7" or 17.8cm diameter reel. The reels are clear in color and is made of polystyrene plastic (anti-static coated).

Dimensions are in millimeter										
Pkg type	A	B	C	d	E	F	P0	P	P1	W
SOT-563	1.78	1.78	0.69	Ø1.50	1.75	3.50	4.00	4.00	2.00	8.00

SOT-563 Tape Leader and Trailer

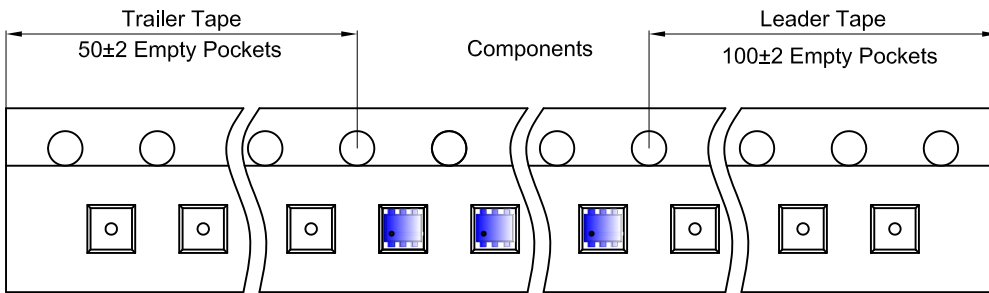

SOT-563 Reel

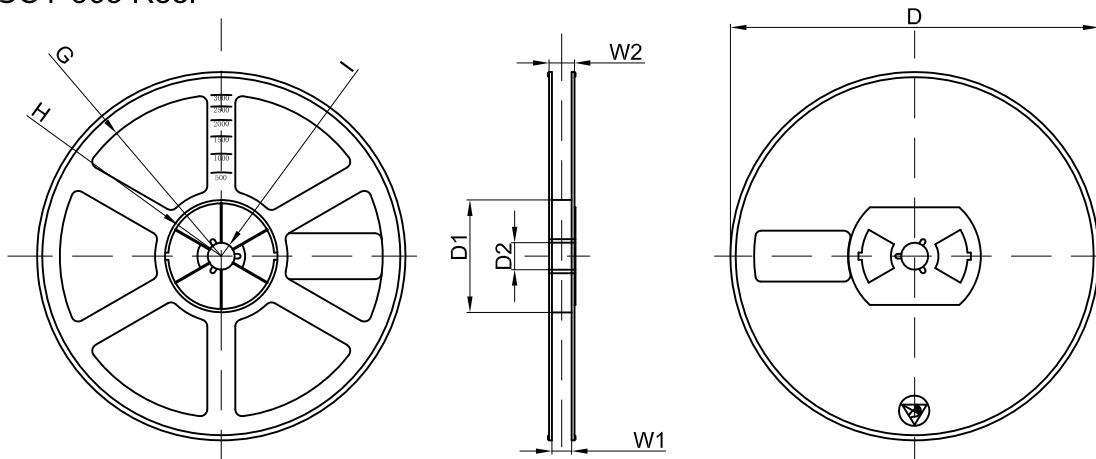

Dimensions are in millimeter								
Reel Option	D	D1	D2	G	H	I	W1	W2
7"Dia	Ø178.00	54.40	13.00	R78.00	R25.60	R6.50	9.50	12.30

REEL	Reel Size	Box	Box Size(mm)	Carton	Carton Size(mm)	G.W.(kg)
3000 pcs	7 inch	45,000 pcs	203×203×195	180,000 pcs	438×438×220	